

Trilogy Machinery Advantages

Since 2009, we have been committed to providing our customers the highest level of professionalism, integrity and service. This commitment is what helped us to achieve our reputation as a leader in the metal fabricating machinery industry.



Sunrise Ironworker and Punching Machine

OEM PARTS & ACCESSORIES

DUAL-CYLINDER | PM | K-SERIES MODELS



DEDICATION

Trilogy is a team of over 15 dedicated and energetic professionals ready to assist with your Metal Fabricating Machinery needs.



SOLUTIONS

We offer solutions to your Metal Fabricating Machinery needs. Our sales technicians are all factory-trained to assist with providing the correct machine for your job.



UNLIMITED SUPPORT

We service what we sell! Trilogy has a massive stock of spare parts and we also offer world renowned technical support by our factory-trained technicians. Customers get free phone support for the life of the machine.



NATIONWIDE DEALERS

In addition to the service and support provided direct from Trilogy, we also have an extensive network of local dealers that are ready to help with on-site service, sales and support.

Contact Information



Product Inquiries

Inquiry@trilogymachinery.com



Technical Support and Service

Service@trilogymachinery.com



Parts

PARTS@trilogymachinery.com



Office and Showroom

4610 Mercedes Drive, Belcamp, Maryland 21017



Mailing

PO Box 70, Belcamp, Maryland USA 21017



Phone

410.272.3600 | 888.988.7655



FAX

410.272.3601

www.Trilogymachinery.com
888.988.7655



Angle and Plate Processing Lines

Horizontal Benders

CNC Punch and Shear

Ironworkers

Metal Fabricating Machinery



SUNRISE K-Series Ironworkers Accessories

Sunrise offers a wide variety of options* and custom tooling. Please inquire!

Punch Station

- Vertical Design
- Many options available including press brakes, pipe notchers, and more!

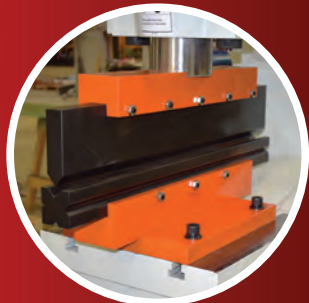

Shear Station

- Vertical Design
- Multiple blade options such as channel, t-bars and unistrut
- Hydraulic Hold-Down standard on 66K/KB/KBN and 95KD

Notcher Station

- Vertical Design
- Vee Notcher and Press Brake Options
- Integrated press brake (66KB) and integrated press brake & notcher (66KBN)

Press Brake Attachment

Press Brake attachments are great additions to the K-series from Sunrise. Choose the multi opening for bending thinner gauge material, or the single-vee for bending thicker plate.

Single-Vee Die – Thick Material

6" wide x 1/4"

IW-50M Part#: SUNIW-9023890

IW-50K Part#: SUNIW-1623300

IW-66K Part#: SUNIW-2923100

8" wide x 3/8"

IW-66KB Part#: SUNIW-8723100

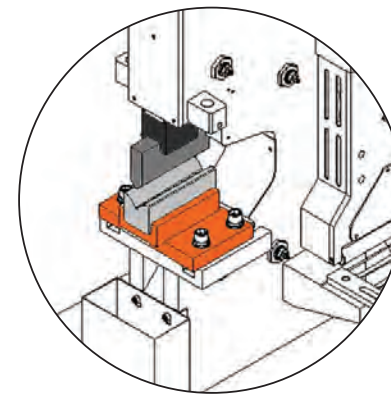

Multi-Vee Die - Thin Material

10" wide x 1/8"

IW-50K Part#: SUNIW-1623400

10" wide x 1/4"

W-66K Part#: SUNIW-2923200

12" wide x 1/4"

IW-66KB Part#: SUNIW-8723000

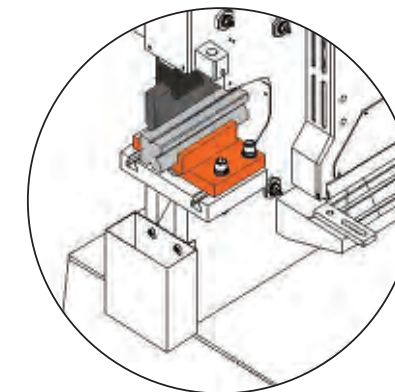

Notcher-End Press Brake

Simple kit for bending small brackets using your notcher station.

IW-50K, 66K

4" x 3/16"

Special Order Item

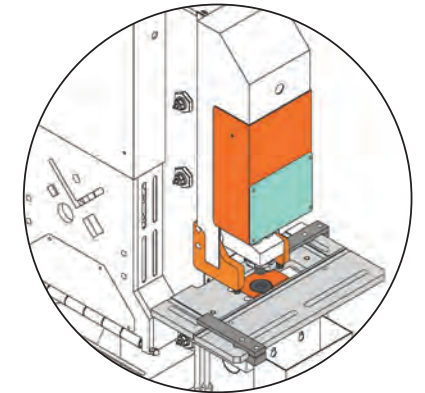

Pipe Notcher/Coping Kit

Did you know your Sunrise Ironworker can put a 90 degree cope on the end of your pipe? This simple attachment takes a specific size of pipe and copes the end to allow you to weld to another piece of pipe the same size.

Kit includes one punch and die for schedule 40 pipe.

All kits include die block and necessary tooling.

Ask us for more information!

* Additional tooling may be required.

* Options vary depending on the model.



www.TrilogyMachinery.com

888.988.7655



SUNRISE K-Series Ironworkers

Urethane Stripper

The urethane stripper enables the operator to punch sheet metal and lighter gauge material by compressing the stripper using urethane springs. The urethane helps to prevent deformation of the punched part.

IW-50K
Part#: SUNIW-STAU
IW-66K/KB/KBN
Part#: SUNIW-STAU2

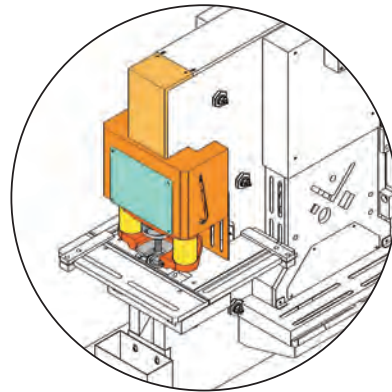

Oversize Punch Kit

The oversize punch kit allows the K-Series machines to punch up to 4" diameter holes (within the tonnage range of the machine), and adds the ability to accommodate larger tooling. The kit includes all necessary adapters to handle the complete range of sizes up to 4".

IW-50K,66K/KB/KBN
Diameters 1-9/16" - 4"
Part number based on model.
Optional Gauge Table Available
Punches or Dies are additional.

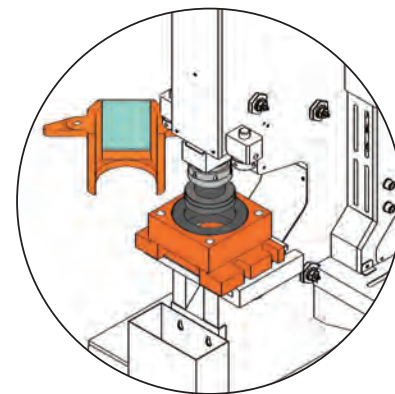

Triangular (V) Notcher

This notcher-end mounted vee-shaped notcher replaces the standard rectangular copier-notcher, and allows the operator to now notch angle and plate with a 90 degree vee-shaped notch.

IW-50K, IW-66K
3.5" x 3.5" x 5/16"
Part#: SUNIW-2921000

Kit includes gauge table and uses same guard as notcher.

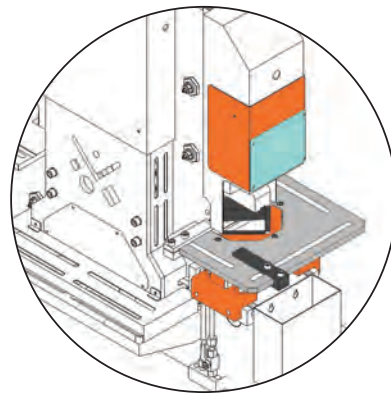

Section Shear

The Sunrise K-Series Ironworker can shear channel and other structural steel as well! Change out your angle shear for the channel shear option and instantly add additional capabilities to your machine!

Channel Blades

Pricing includes front and back blade, and safety cover.

IW-66K/KB and IW-95KD include hydraulic hold-down cut-out.
Custom profiles available upon request.

IW-50K - 3" Channel - Part#: SUNIW-1622300

IW-66K/KB

2" and 3" Channel - Part#: SUNIW-2922230

4" Channel - Part#: SUNIW-2922400

IW-95KD - 3", 4", 5", 6" Channel (One Size Only)

Various Part Numbers - Inquire please.

Did you remember to order sleeves,
spanner wrench, or other punch tooling?
We're here to help!



www.TrilogyMachinery.com
888.988.7655



SUNRISE Dual-Cylinder Ironworkers & Punching Machines

Punch Station

- Built for speed and versatility
- Many options available
- Large open space for custom tooling
- Many CNC Punch Options



SUNRISE

Angle and Structural Shear Stations

- Dedicated stations for angle and structural shear
- Multiple inserts for various beams, channel, round/square bar

Notcher Station

- Vee-Shaped Notchers

Plate Shear Station

- Hydraulic hold-down optional
- Support Table
- Back-gauge Extensions
- CNC Shear Option

Sunrise offers a wide variety of options* and custom tooling. Please inquire!

* Options vary depending on the model.

SUNRISE

SUNRISE Dual-Cylinder Ironworkers & Punching Machines



Channel, T-Bars, Unistrut, or custom blades? Ask us for a quote today on special shearing blades for your Sunrise!

Schedule 40 Pipe Notcher Kit S/SD/KD/PM

Quickly add the ability to notch/cope the end of your pipe at 90 degrees with your Sunrise Ironworker! The standard uses the quick-change tooling for maximum versatility and ease.

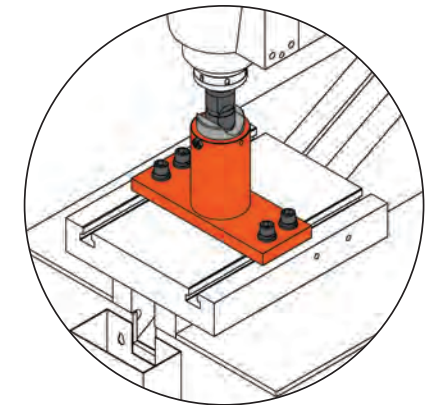

Section Shear

The Section Shear of your Sunrise Ironworker is a true work-horse with the ability to shear channel, I-Beam, and other structural steel! Custom profile? No problem! Send us your CAD drawing and our engineers will create a custom quote for your machine.

Other Profiles also available including Unistrut, T-Bar, Beam, Custom Round/Square Solid Rod and more!

Triangular (V) Notcher Kit (Notcher End)

3.5" x 3.5"

IW-66S/SD – Part#: SUNIW-3221000
3/8" Mild Steel Capacity

IW-88S/SD – Part#: SUNIW-3221000
1/2" Mild Steel Capacity

4" x 4"

IW-110S/SD-135S/SD
Part#: SUNIW-3421000
1/2" Mild Steel Capacity

IW-185SD – Part#: SUNIW-3821000
5/8" Mild Steel Capacity

*Kit includes machined gauging table
Not applicable for Punching Machines*

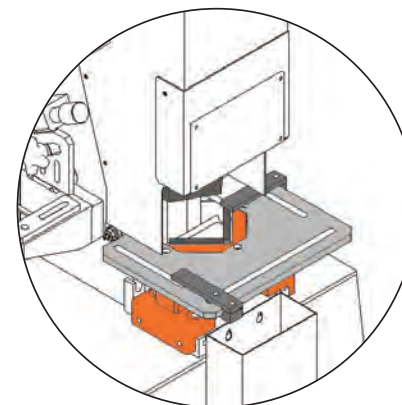

Large Triangular (V) Notcher

Mounted on the punch station of any dual-cylinder ironworker or PM model, this large vee-notcher easily takes a massive notch from flat plate and angle.

Single-Vee Die – Thick Material

All S/SD and PM Models

5.5" x 5.5"

Part#: SUNIW-9021400

Capacities:

5/16" - 38-66 Ton Models

3/8" - 88 Ton Models

1/2" - 110-220 Ton Models

Kit includes gauge table and urethane hold downs. Adjustable blade gap.

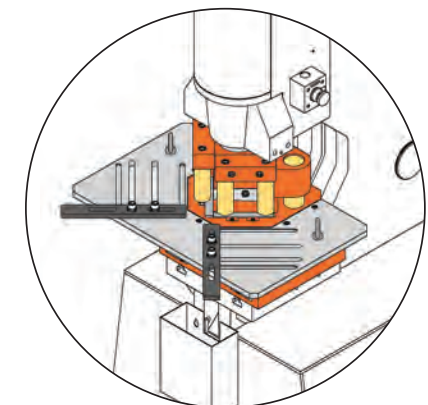

www.TrilogyMachinery.com

888.988.7655



SUNRISE Dual-Cylinder Ironworkers & Punching Machines

Press Brake Attachment

Press Brake attachments are great additions to the S/SD/PM series machines from Sunrise. Choose the multi-opening for bending thinner gauge material, or the single-vee for bending thicker plate.

Multi-Vee Die – Thin Material

IW-66-88, PM-38-88

20" wide x 3/16"

Part#: SUNIW-9023590

Oriented front to back

IW-110-185, PM-135-220

27.5" wide x 3/16"

Part#: SUNIW-9023690

Oriented left to right

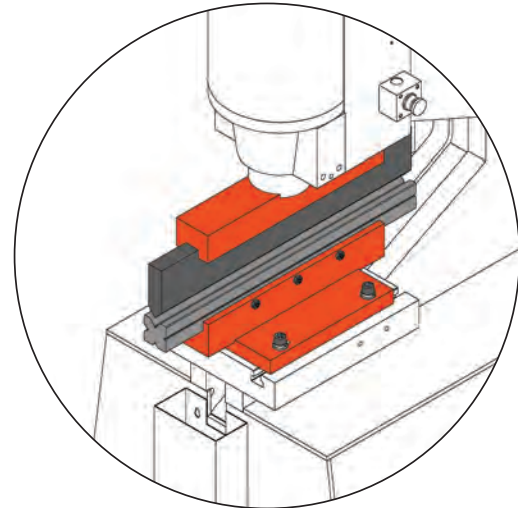

Single-Vee Die – Thick Material

IW-66-88, PM-38-88

10" wide x 1/2" Capacity

Part#: SUNIW-9023490

Oriented front to back

IW-110-185, PM-135-220

10" wide x 3/4" Capacity

Part#: SUNIW-9023901

Oriented front to back

IW-110-185, PM-135-220

20" wide - 1/2" Capacity

Part#: SUNIW-9023990

Oriented front to back on SD/LT/XT and
left to right on S/T

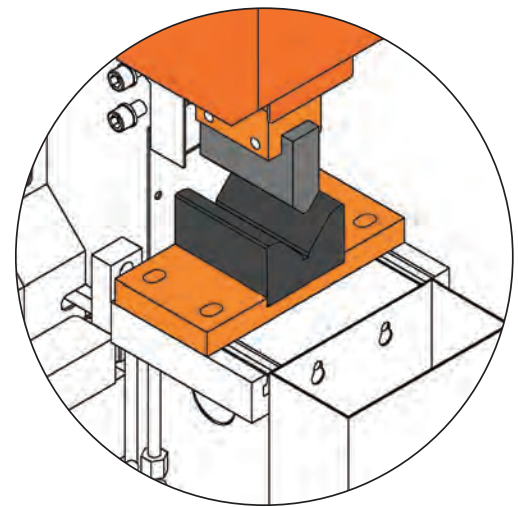

All standard Sunrise ironworkers and punching machines feature a t-slot bed to easily slide in various attachments, such as press brakes!

SUNRISE Dual-Cylinder Ironworkers & Punching Machines

Did you know your Sunrise ironworker or punching machine can process channel and angle, leg-up?
Ask us about the Channel and Angle Leg-Up Stripper!

Oversize Punch Kit

Diameters 2" - 4"
(Part Number based on model)
Diameters 4" - 8"
(Part Number based on model)
Complete 2" - 8"
(Part Number based on model)
Gauge Tables Available

Individual pieces are available, but may be at a higher cost than the kit price.
Kit does not include punches, dies, or gauge table.

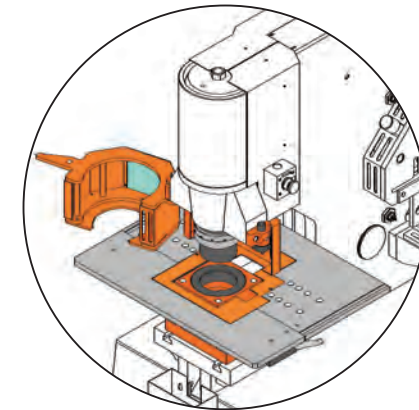

Urethane Stripper

The urethane stripper enables the operator to punch sheet metal and lighter gauge material by compressing the stripper using urethane springs. The urethane helps to prevent deformation of the punched part.

IW-S/SD/PM
Part#: SUNIW-STBU

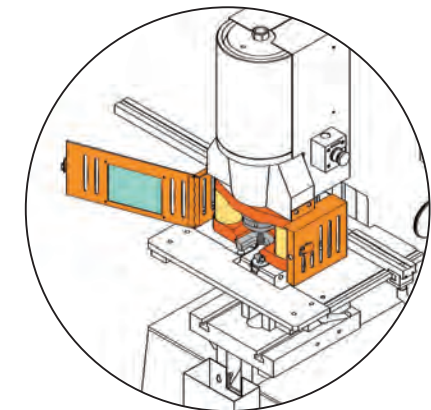

Channel/Angle Leg-Up Stripper

One of our most popular accessories, the Channel and Angle Leg-Up Stripper allows the operator to punch holes in channel webs with the flanges up as well as punch holes in angle with the leg-up, to gauge from the heel, rather than only leg-down. Uses standard SP1 Punches and Dies. Standard capacity is 3" - 6" channel web/angle leg-up. Optional smaller strippers available to punch down to 1" channel web/angle leg-up.

IW-S/SD/PM

Part#: SUNIW-STBCH-S/SD Kit
Narrower leg-up strippers exist, please inquire.

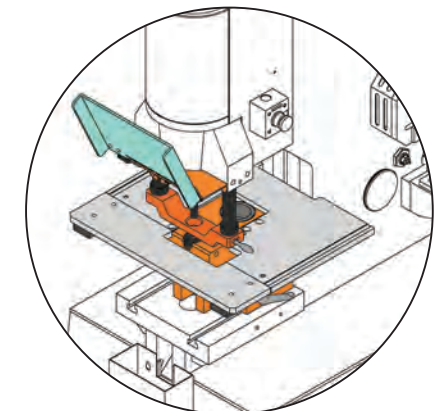

SUNRISE Dual-Cylinder Ironworkers & Punching Machines

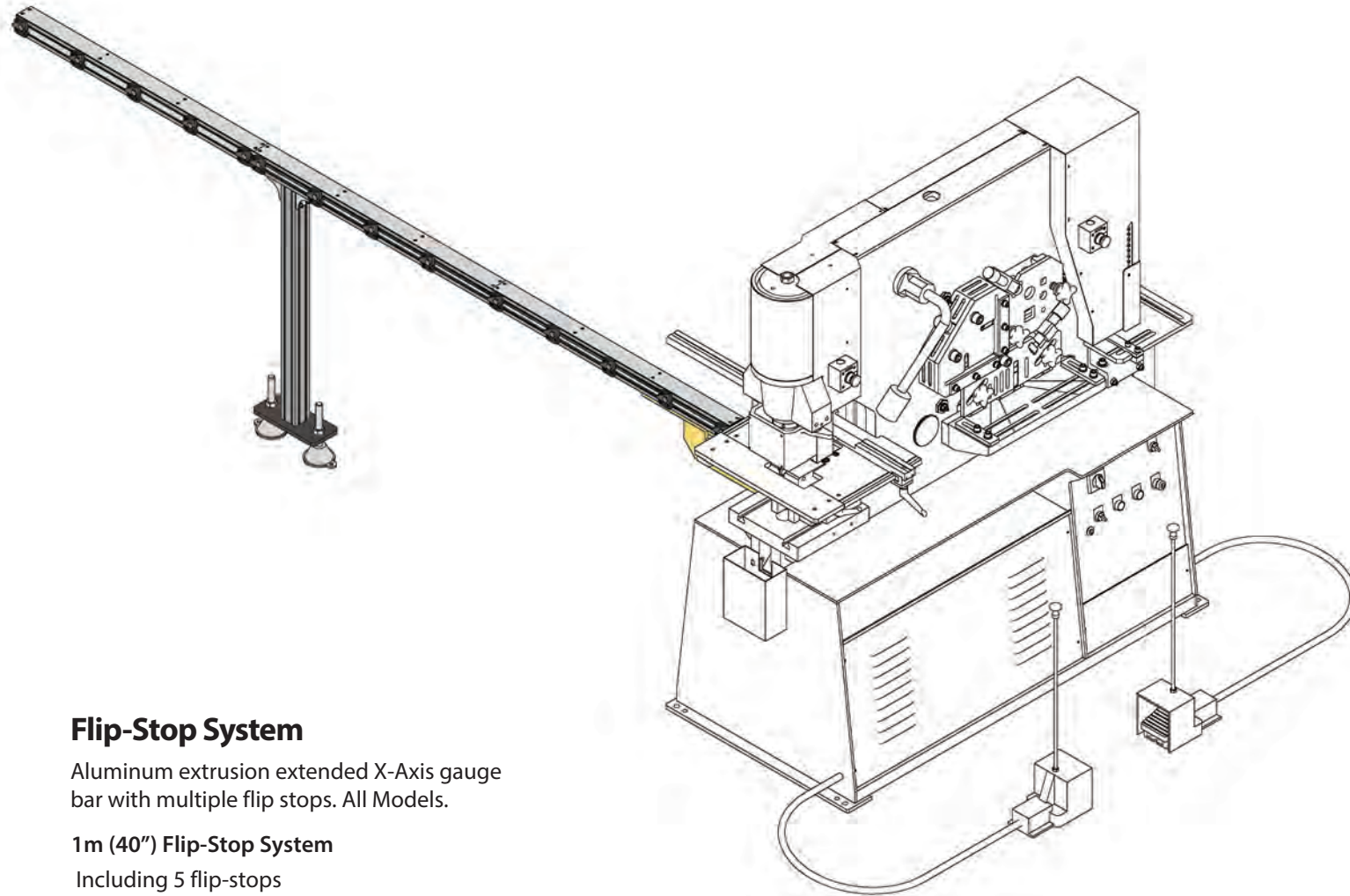

Flip-Stop System

Aluminum extrusion extended X-Axis gauge bar with multiple flip stops. All Models.

1m (40") Flip-Stop System

Including 5 flip-stops
Part#: SUNIW-819102991

2m (80") Flip-Stop System

Including 10 flip-stops and 1 support stand
Part#: SUNIW-819102992

3m (120") Flip-Stop System

Including 15 flip-stops and 2 support stands
Part#: SUNIW-819102993

Electric Back Gauge (Dual-Cylinder Models)

1m (40") Electric Back Gauge
Part#: SUNIW-1311300

2m (80") Electric Back Gauge
Part#: SUNIW-1311400

3.7m (144") Electric Back Gauge and support stand
Part#: SUNIW-1311710

Need some Sunrise or Trilogy Machinery swag?
Ask us! We want you to feel proud owning and
operating your Sunrise machine!



www.TrilogyMachinery.com
888.988.7655

